



**SPARCO FORMULA ROTAX 125
LIGHT AND HEAVY
NATIONAL SPRINT KART CHAMPIONSHIPS
SUPPLEMENTARY REGULATIONS**



1. Authority

The meeting will be held under the International Sporting Code of the FIA, the General Karting Regulations of the AKA and any further addendums and bulletins to the regulations.
Refer Rules 1.07 and 11.02

AKA Permit Number: - AKAFNR05/08

2. Organisers

Go-Kart Club of Victoria

3. Dates and Place of Meeting

VACC Park Todd Road, Port Melbourne
Circuit Layout - Hot mix Bitumen
Track Length – 960 metres x 8 metres
Race Direction – Anti-Clockwise
Track Density – 36
5th/6th/7th September 2008

4. Officials of the Meeting

Clerk of Course:	Graeme Monds
Chief Steward:	Chris Robinson (QLD)
Interstate steward:	Chris Robinson (QLD)
Stewards:	Harold Arnett, Les O'Connor, Arthur Etherington Fran Kelsall, Sylvia Stania
Stewards' Secretary:	Pam Arnett
Secretary of meeting:	Stella Pringle
Announcer:	Rod Sheppard, Ian Salvestrin
Starter/s:	Mark Newman
Chief Lapscorer:	Margaret Uhlhorn
Lap Scorers:	Verlie Bryer Stella Pringle, Denise Wall
Chief Timing Officer:	Doug Wilson
Transponder Marshall:	Rosemary Grace
Judge of Fact:	As per rule 4.17
Scrutineers:	Gary Haythorpe & Assistants
Grid Marshall:	Anita Lowerson Susan McDougal
Technical Inspectors:	Glen Lowther, Alan Handley
Flag Marshall's:	Geelong Flag Marshall Group
Scales Marshall:	Janette Monds
Medical Service:	St,John First Aid

5. Classes to Compete Rotax Nationals:

Formula Rotax 125 Light @ 160kgs – AKA A or B Grade License
Formula Rotax 125 Heavy @ 180kgs – AKA A or B Grade License

6. Entry:

A Championship Entry Fee shall be \$ 465 including GST per kart, per class. The entry fee includes a set of MOJO D2 tyres for tyre pooling as per rule 23.11
N.B. The fee includes one driver pass, 2 pit crew passes, and engine and chassis seals.

B Eligibility - The minimum grade of licence will be AKA (A and B) for Championship Classes. No C Grade or Provisional licences accepted except in Support Classes.

C Close of entries: Entries close the **14th August, 2008.**
Entries post dated on the close of entry date will be accepted. All entries must include a completed AKA entry form, and entry fee. **Cheque or money order only. No late entries will be accepted.**

Entries will only be eligible for refunds if entry is cancelled in writing before close of entries, or if the class is cancelled as per rule 20a:08 (c)
All entry information will be distributed at Drivers Entry Confirmation
(Passes, engine seals, etc) will not be mailed out.

D Post entries to:

<p>Race Secretary Go Kart Club of Victoria PO BOX 111 YARRAVILLE VICTORIA 3013</p>

E Race numbers:

Numbers 1, 2, and 3 are reserved for current National Championship place getters in their respective classes. Race numbers will be allocated when entries are received. Kart numbers are to be displayed on both right hand and left hand side pods.

F Driver sign in:

All drivers must report to the Race Secretary to confirm entry and scrutineering.

G Track Closed:

Track will be closed from Friday 29th August to Thursday 4th September to those competitors in the Rotax Nationals Classes.

7 Minimum Entries:

The minimum number of entries per class shall be 14.
If insufficient entries are received the class will be cancelled, as per rule 20A.08 (c) and competitors will be notified by phone.

8. Format of Racing

1 ROTAX CHAMPIONSHIP CLASSES - UNDERSUBSCRIBED

1. Two (2) X timed qualifying sessions three (3) heats, pre final and final. Finishing order of the final determines the positions in the Championship class.

(a). Two (2) X four (4) minute timed qualifying sessions (refer Rule 19:17)

(b). Heat one: Grid positions as per qualifying (fastest time to grid position one, and so on) (c). Heat two: Grid positions as per qualifying (fastest time to grid position one, and so on) (d). Heat three: Grid positions as per qualifying (fastest time to grid position one, and so on) Each heat to be run over a distance of twelve (12) laps.

(e). One (1) Pre-final: lowest points from the three heats to grid one and so on. Ties of points from the heats will be decided by qualifying times. The pre-final to be run over a distance of sixteen (16) laps

(f) One (1) Final: The finishing order from Pre final will be the grid order for the final. Non finishers from the Pre final will be gridded at the rear of the field in order of laps completed, then grid position from the Pre final. The final will be run over a distance of twenty-one (21) laps.

(g) All competitors must register a qualifying time and compete in one heat to be eligible for positions for the Pre-Final and the Final.

(h) Karts underweight will be excluded (refer Rule 5:03) except during timed qualifying then Rule 19:17 (e)

(i) Ties between karts on points from Heats will be decided by their timed qualifying position.

(j) Point Score System for Heats: 1st 0 Points 2nd 2 Points 3rd 3 Points and so on with one point being added for each place.

ROTAX CHAMPIONSHIP CLASSES - OVER SUBSCRIBED:

2. Oversubscribed classes must be split into two groups for qualifying. The two groups shall be determined by the race number of the entrant, being either odd or even. For the first qualifying session the odd numbers group shall be first. In the second qualifying session, the even number group shall be first

A) Two (2) X four (4) minute timed qualifying sessions (refer Rule 19:17)

a) The driver who records the fastest time from either Group will be identified as the pole sitter.

b) The driver who records the fastest time from the "other" Group will be identified as the second fastest time overall.

c) The driver who records the second fastest time from the pole sitter Group, will be identified as the third fastest time overall

d) The driver, who records the second fastest time from the "other" Group will be identified as the fourth fastest time overall.

e) This process of determining the ranking of driver's times shall continue as per the above method for the entire field

All drivers recording a valid qualifying time will be split into groups A, B, C, & D etc. The number of groups is dependant upon the number of entries. EG. 33 – 48 entries = 3 groups, 49 – 64 entries = 4 groups etc.

Fastest to group A, second to group B, third to group C, fourth to group D, fifth to group A, sixth to group B and so on until all qualifiers are allocated to a group. Each of the groups mentioned above will race with the other groups, in other words, A with B, B with C, and A with C etc. At the end of the heats the drivers with the lowest points will progress to the finals. Each heat to be a minimum of ten (10) laps.

- B. Pre Final of sixteen (16) laps consisting of the top thirty-two (32) placed competitors with the lowest points from the qualifying heats. Grid positions will be determined by the heat scores with the lowest points to the front. Ties of points from the heats will be decided by qualifying times.
 - C. Final of twenty-one (21) laps grided as per the finishing order of the Pre Final. Non finishers will be grided at the rear of the field in order of laps completed in the pre final. Finishing order of the final determines the winning positions in each class.
 - D. All competitors must register a qualifying time to be eligible for positions for the Pre Final and Final.
3. Karts underweight will be excluded (refer Rule 5:03) except during Timed Qualifying, refer Rule 19:17(e) applies
 4. Point Score System for Heats. 1st 0 Points. 2nd 2 Points. 3rd 3 Points, and so on with one point being added for each place.
 5. Non - starters and non- finishers to be awarded a finishing position based on the number of laps completed then the grid position awarded from the start of the heat.

9. Timetable (Proposed only, subject to change)

Scrutineering will be conducted throughout the entire event – competitors are reminded that karts MUST comply at all times.

<u>Thursday September 4th</u>	Track available for pitting	6.30pm -5.00pm
	Track available for unofficial practice	8.00am-5.00pm
<u>Friday September 5th</u>	Track open for pitting	6.30am
	Track available for unofficial practice for All Classes	8.00am-5.00pm
	approx. 8 minute rotating sessions with support classes having an 8 minute session after each national class .	
	Confirmation of Entry/Scrutineering also for the Issue of passes and tyres	2.00pm-5.00pm
<u>Saturday September 6th</u>	Official Practice/All Classes	8.00am –9.30am
	Drivers briefing	9.45am
	Qualifying (2 x 4mins)	10.00am
	Heats Races	
	Entertainment/Dinner Party	TBA
<u>Sunday September 7th</u>	Carby session	9.00am – 9.30am
	Drivers briefing	9.45am
	Racing Continues	10.00am
	Official Presentations	TBA

10. Blue and red double diagonal flag:

The blue and red double diagonal flag will be used during this meeting. (Refer rule 15:13)

11. Abandonment or postponement:

The organizers reserve the right at their sole discretion to abandon, postpone or cancel any events subject to rule 11.09.

12. Prizes:

Trophies will be awarded to 1st, 2nd, 3rd, 4th & 5th in all Rotax National Championship classes. Green Plates will be awarded for champions in Rotax Light and Rotax Heavy classes. An award will be given to the fastest time trial in each Rotax National Championship class.

13. Insurance:

Insurance has been affected for this event in accordance with chapter 3.

14. Noise levels:

Maximum permissible noise levels shall be in accordance with chapter 24.

15. Fuel (refer Rule 25.14):

Control Fuel (refer Rule 25.14) for these Championships is **Shell 'V' power** - (*please note: not V power racing*) All control fuel must be purchased and used between Saturday 6th September and Sunday 7th September 2008 inclusive from the Shell Service Station, Cook Street (Track side) Port Melbourne.

Fuel testing in accordance with rule 22.01, using the digatron, may be undertaken during any section of the competition, with samples being taken and tested for conformity against samples provided from the nominated supplier. Based upon the results of the digatron tests a complaint to the stewards of the meeting may be made under rule 5.01(q). Competitors are reminded that fuel tanks and storage drums should be emptied prior to being filled with fuel being purchased for this meeting to avoid contamination from previously purchased fuels.

16. Judges of fact:

As per Rule 4.17(a)

17. Pit shelters:

Pit space is restricted to 3m x 3m per kart

18. Trade Space:

Trade will be allocated space in a designated trade area.

19. Tyre Pooling:

Tyre pooling will occur at this meeting as per rule 23:11

It is the driver's responsibility to collect his/her tyres between the stated hours.

All tyres will be marked with a unique id. Any deterioration to the control markings on the tyres, after fitting the tyres, must be reported to the scrutineer immediately for rectification.

NB. All competitors are to supply their own wet weather tyres and must present them for marking to the tyre distribution centre or nominated area when directed.

In the case of tyres being lost or damaged, the promoting club may issue replacement(s), (at the cost of the competitor) only on instruction from the stewards of the meeting. As per rule 12.01 and 12.02 inspection of equipment maybe carried out at anytime during the event.

20. Engine Sealing:

All Rotax motors are to be fitted with 2 drilled cap screws. 1 in the reed block, 1 in the water cover and the back barrel stud on the drive side drilled with a 2.5mm hole to allow the sealing wire to be fitted in order to seal the engine prior to scrutineering.

Engines to be used in racing as per rule 19:33 8 and sealed as per 20a:12. Rotax seals to be fitted by officials

21. Transponders / holders:

Drivers with personal transponders **must** advise at time of entry conformation, with AMB transponder number, (7 digit). **AMB TranX 260 transponders can also be used.**

AMB TranX 160 transponders will be used throughout the event for timed qualifying and racing. **All karts must have a transponder holder fitted.** Transponder holders will be available for purchase at the circuit, at a cost of \$10, including fitting bolts, nuts, washers and transponder retaining clip.

Location of transponder bracket, [30cm from king-pin]. Fix the bracket **vertically** with no metal or carbon fibre beneath, (plastic is OK).

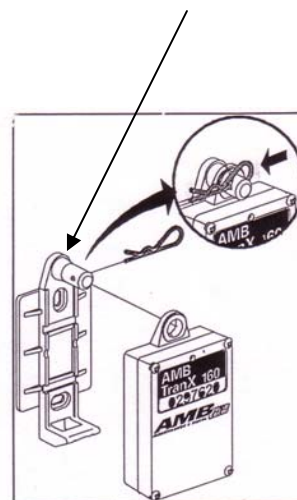
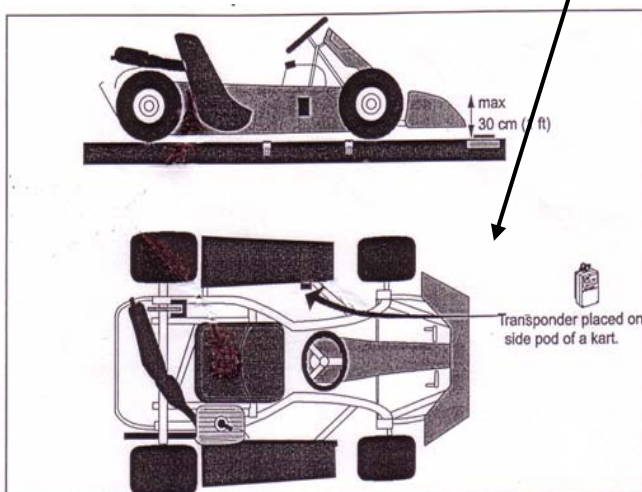

Fixing the transponder
Fasten the transponder in the holder using the supplied fixing pin. Push the pin all the way through

Warning: A detached transponder can be very dangerous. Make sure the transponder and holder can not get detached. Use additional tie-wraps during endurance races.

Transponders must be fitted facing the driver, on the left hand side pod, 30cm from the king pin as shown above.

Drivers must:

1. Collect their allocated transponder from the appointed timing official / grid official
2. Correctly fit and use the transponder during qualifying and/or racing
3. Return the transponder to the appointed official at the end of each race or qualifying session, unless directed otherwise, (refer rule:- 19.17 (d)).

Drivers may be penalized for failure to use or correctly fit the allocated transponder for any event during the course of the meeting

22. Support Classes to Compete:

- Formula JMA @ 145kg
- Formula Rotax O35's @ 170kg
- Junior National Light @ 120kg
- Rookies @ 105kg

23. Entry:

A Entry Fee is \$90 per kart

B Close of entries: Entries close on Wednesday the **3rd September, 2008.**
Entries post dated on the close of entry date will be accepted. All entries must include a completed AKA entry form, and entry fee. **Cheque or money order only.**
Entries will only be eligible for refunds if entry is cancelled in writing before close of entries, or if the classes are cancelled as per rule 20:12(c)
All entry information will be distributed at Drivers Entry Confirmation (Passes, engine seals, etc) they will not be mailed out.

D Post entries to:

**Race Secretary
Go Kart Club of Victoria
PO BOX 111 YARRAVILLE VICTORIA 3013**

24. Minimum Entries:

The minimum number of entries per class shall be 8.

If insufficient entries are received the class will be cancelled, as per rule 20.14 and competitors will be notified by phone.

25. Format of Racing:

Classes will be formed with **the first 36 entries received for each support class.** There will not be a recharge for support classes. Classes will be grided Draw and Reverse for Heats 1 & 2 with lowest points to the front for heat 3

**3x Heats of 10 Laps
1x Pre Final of 12 laps
1x Final of 16 Laps**

Point Score System for Heats: 1st 0 Points 2nd 2 Points 3rd 3 Points and so on with one point being added for each place.

Non- starters and non- finishers to be awarded a finishing position based on the number of laps completed, then the grid position awarded from the start of the heat.

26. Blue and Red double diagonal flag:

The blue and red double diagonal flag will be used during this meeting. (Refer rule 15:13)

27. Abandonment or postponement:

The organizers reserve the right at their sole discretion to abandon, postpone or cancel any events subject to rule 11.09.

28. Prizes:

Trophies will be awarded to 1st, 2nd and 3rd Place getters

29. Insurance:

Insurance has been effected for this event in accordance with chapter 3.

30. Noise levels:

Maximum permissible noise levels shall be in accordance with chapter 24.

31. Cycles in the Venue:

There will be NO RIDING of push cycles, scooters, motorised scooters, skate boards, mini bikes or similar apparatus in the grounds at any time (officials and disabled persons excepted). Any person or persons found riding or operating any apparatus within the grounds will have the apparatus confiscated and it will not be returned until the completion of the meeting.

32. Animals in Pits:

Animals are prohibited with the exception of security companies guard dogs.

33. Security:

Security will be provided from 7pm to 6am **Thursday 4th September** through to **Sunday morning 7th September 2008**

Gates will be locked 1 hr after the completion of each day's events.

Gates will be unlocked at 6:30am from Thursday 4th Sept through to Sunday morning 7th Sept
-TODD ROAD GATES will also be open for track entry (due to peak hour traffic.)

34. Camping:

At the venue is strictly prohibited as per council by law.

35. Canteen:

Canteen facilities will be available from Thursday 4th to Sunday 7th September 2008.
Breakfast will be available Saturday and Sunday

36. Parking - Cars, Vans and Trailers, etc:

Cars and Trailers All trailers are to be disconnected from tow vehicles in the Pit Area and those tow vehicles parked in the designated park area **NO CARS ARE PERMITTED IN THE PIT / PADDOCK AREA AT ANY TIME.** Trade vehicles are only permitted in the Pit area at the discretion / approval of the organisers and must be placed in the designated Trade Area. - Access to the Pit / Paddock area will not be available once the competition commences. Exceptions are club officials, officials, disabled and authorised vehicles only. There will be specified parking areas for these exceptions.

37. Electricity:

Competitors must provide own generator for lighting/power.

38. Kart Specifications:

Shall be in accordance with the 2008 AKA Karting Manual and subsequent amendments. These Supplementary Regulations are to be read in conjunction with the General Standing Regulations and Australian Kart Formula for Sprint Racing as laid down in the AKA 2008 Karting Manual and Official Entry Form.

39 Promotional Activities:

On track promotional activities will be held during the course of the weekend
DD2 Rotax Kart demonstration – V8 Super car drivers - 4 x 5laps
Driver Parade
Promotional activity staff
National TV coverage
Professional Singer for the National Anthem & evening dinner
Post racing BBQ dinner / Music

40. For Further Enquiries please contact:

Stella Pringle:	Race Secretary	Mobile: 0408563838 Email: pringle3@bigpond.net.au
Peter Rowsell:	Secretary:	Home: 03 9741 8690 Email: info@gkcv.com.au
John Wall:	President:	Mobile: 0411889402 Email: john@eaglelighting.com
General Club Information		www.gkcv.com.au